

# FeMBMS Repeater Solution

Further evolved Multimedia Broadcast Services (FeMBMS) released by 3GPP (Rev. 14) demand new frequencies for repeaters in indoor or outdoor areas. We have now expanded our VBI portfolio by creating a market-unique FeMBMS repeater.

## Product Description

FeMBMS is also known as “5G-XCast” focuses on future distribution of media content in broadcast based on mobile technology. Introducing this technology allocates new broadcast frequency bands and introduces new cell coverage challenges.

Based on the field-proven VBI family, our FeMBMS repeater is characterized as a highly integrated and cost-effective solution for cell extension covering shadowed areas or indoor locations.

Up to four independently configurable sub-band filters per channel with automatic gain control can be configured by a web interface. Thus, on-site FeMBMS service selection is made easy.

Each sub-band input signal level is constantly monitored. Low signal levels may trigger configurable alarms over various interfaces.

## Functional Diagram

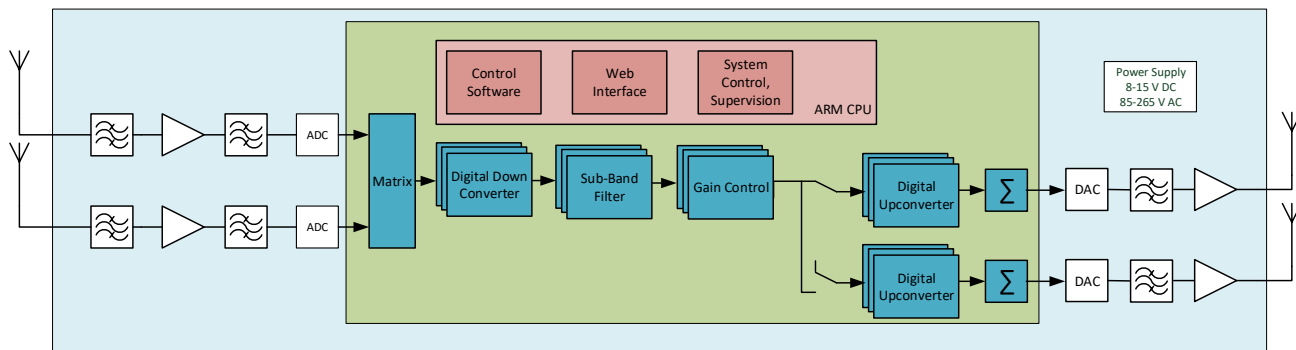

## Benefits & Highlights of our Solution

- ▶ Standalone repeater
- ▶ **Configurable sub-band filters**
- ▶ **Dual individual RF** channels for two zones
- ▶ **Automatic gain control per sub-band** and precise RF input level measurements
- ▶ **Second RF receiver** for monitoring RF signals or a fully redundant setup
- ▶ **Low power** consumption (15 W typ.)
- ▶ **Web management** for control and monitoring
- ▶ **Future-ready:** signal processing fully embedded in hardware as programmable FPGA cores
- ▶ **Various interfaces**, alarm outputs for signal loss, or customizable inputs/outputs
- ▶ Compact module or 19" device available
- ▶ **High reliability (MTBF)** – thanks to a very slim system design
- ▶ All-in-one hardware solution

## All-in one hardware: improved reliability and low power

To guarantee high reliability, long-term operation, compact size, and low power consumption, our system follows a simple yet powerful approach where the complete hardware is downsized to just a few, but of the highest quality components. We're not ready to make compromises when it comes to quality.

All electronic parts are contained on a single board, from RF input, digital signal processor, to the RF output.

Sub-band filters and automatic gain control are completely hardware-based IP-cores, running on an FPGA without the need for an embedded computer.

Our dedicated RF frontends in conjunction with the high-speed analog to digital converters allows us covering the whole FeMBMS Band at the full bandwidth of 80 MHz with processing capabilities of **up to 4 sub-band channels**.

### Repeater Specification

Frequency range (FeMBMS)	610 - 690 MHz
Number of repeater channels	4
RF output power	-30 - +3 dBm
Gain	75 dB max.
Adjacent channel suppression	> 80 dB
Out-of-band suppression	>55 dB
Noise figure	< 10 dB
Group delay	7 us
Typical power consumption	15 W
Supply voltage (module)	8-15 V DC
Supply voltage (rack version)	85-264 V AC
Operating temperature	0-50 °C
MTBF	260900 h
Long-term availability	At least until 2030

## Mechanical: Robust Housing

For optimal heat transfer and RF shielding, everything is enclosed in a compact, fully milled aluminum case. For custom system integration, the VBI solution can either be

delivered as a module (figure above) or, if preferred, completely assembled in a 19" rack-mountable chassis including an AC power supply and cooling fan.

### Chassis

Size (module, no power supply)	210x155x40 mm
Size (rack version)	483x88.1x280 mm (19", 2HU)



Our compact, fully integrated FeMBMS repeater module. Multi-ensemble processing, IP connection, low power consumption and a robust, RF safe casing are just some of the features we offer.



RF Interface at the module: dual RF-input, clocking and dual RF-output. E.g. our hardware also allows the independent operation of two tunnel tubes.

## RF Specifications

The RF inputs and outputs both offer two channels and are connected via SMA (module version) or customized according to your needs (19" rack version).

Apart from a clock reference input, we offer a high-precision, lowest phase-noise clock reference output to

synchronize other devices. **GPS is not needed** to operate the device in repeater mode. However, for specific applications, an optional GPS module can readily be mounted for improved long-term clock output stability.

### RF Input (2x)

Impedance	50Ω
Connector type	SMA
Max. input level sum	-10 dBm
IIP3 (0dB)	-7 dBm
IIP3 (15dB)	7 dBm
Input ESD protection	
S11	<-10 dB
Input attenuator	0..31.5 dB (0.5 dB steps)
Max. level meas. error	±0.2 dBm

### Ref. Clk In

Impedance	50 Ω
Max. input power	10 dBm (2 Vpp)

### RF Output (2x)

Impedance	50Ω
Connector type	SMA
Max. output level sum	6 dBm
S22	<-9 dB
OIP3	>30 dBm
Max level set error	±0.2 dBm

### Clock Output

Impedance	50 Ω
Output frequency	Programmable (0.22 – 2370 MHz)
Total Jitter [rms]	120 fs typ.



Modular, broadband RF Interfaces (up to 150MHz RX- and 600MHz TX-bandwidth) make our system ready for you customized frequency needs. Contact us with your specifications.

## Whatever your interface needs are – we’ve got your back!

The system per default is set to indicate and output alarms in case the reception of one, multiple, or all channels are below a defined threshold or too weak.

Besides the Gigabit Ethernet connection, we offer both isolated RS485 with CAN support as well as isolated I2C and customizable GPIOs.

### Configuration and Control

Full control over the hardware configuration as well as the mode control and Voice Break-In functionality is provided via a Web-Interface. For secure systems where no Ethernet access is desired, the hardware can easily be set up via USB-UART, and new firmware is simply loaded by replacing an SD card or by a USB-stick and the push of a button. SNMP is available.

### Redundant Setup Possibility

Thanks to the optional second RF receiver a fully redundant setup with two independent repeaters is possible. In normal conditions, the RF signal from the master device output will be selected with a relay. The slave device monitors that signal and in case of fault switches over the relay.

### Industrial 19" Enclosure

We have a 19" 2HU enclosure (depth 343mm) with an integrated power supply and fully isolated I/Os available from stock. Ask us for more.

### What else?

In case you need different frequency ranges, intrusion detection, localized operation restriction, precise clock generation, reflected power sniffing, or even a GSM connection to the device, please talk to us!

We're there to enable your desired features and discuss any needs you might have.

#### Other Interfaces

Ethernet	RJ45, 1 GBit/s
GPIO	8 channel open collector or digital IO
RS485	CAN support
Fan connectors	2x at Vcc, 300 mA max.
USB	1x Host, 1x UART

#### System control and operation

Web-interface	configuration and control
Firmware Update	SD-card, USB, Ethernet
SNMP	Break-in control, status and alarms



## Hardware Products & Options

Product Code	Description
<b>VBI-FeMBMS</b>	<b>FeMBMS Hardware-Module</b>  FeMBMS channel selective repeater, base hardware module with ethernet, SNMP, web interface, stereo analog audio IO, 7x GPIO
<b>VBI-RACK</b>	<b>Enclosure 19 inch 2U</b>  Enclosure 19 inch 2U with integrated 90-264 VAC power supply for one FeMBMS module and IO board with isolated stereo audio XLR I/O, 4 isolated switching inputs and 4 relays
<b>VBI-2PS</b>	<b>Option Redundant Power Supply</b>  Option second power supply with supervision
<b>VBI-FAN</b>	<b>FAN Kit</b>  2 pcs fans 80x80x25 mm with tacho signal, connector and 280 mm cable length

## Software Options

Software options can be unlocked by entering a keycode in the web interface.

Product Code	Description
VBI-FeMBMS-2TRX	Option dual channel Option dual simultaneous repeater channels

**Contact:**  
PrecisionWave AG  
contact@precisionwave.com  
+41 32 513 57 50